

Instruction Manual
HST SYNCHRO

TABLE OF CONTENTS

1. Applicability	3
2. Safety measures and rules of behavior	3
3. Definitions	4
4. Application	4
5. Specifications	5
6. Unpacking	5
7. Operation	5
7.1 Assembly and clamping	6
7.2 Unclamping of the cutting tool	9
7.3 Insert and change of the MQL tube	10
7.4 Mounting and adjustment of AES screws	12
8. HST SYNCHRO QCA 40 / 60	14
8.1 Assembling and clamping	14
8.2 Insert quick change adapter	14
9. Maintenance	15
10. Care	15
11. Checklist for optimal Tapping	15
12. Checklist for optimal thread forming	15

THANK YOU FOR CHOOSING BASS TAP HOLDERS.

Please read the following safety measures and instruction manual completely and carefully. As a result, you avoid injury through improper handling and achieve time saving and best production results.

Consider the technical data of HST SYNCHRO. The product should only be used in this field. Any possible print errors or changes occurred in the meantime, do not entitle to any claims.

1. APPLICABILITY

This instruction manual applies to:

- HST SYNCHRO 10 / 20 / 40 / 60 / 80 / 100
- HST SYNCHRO 40 / 60 QCA
- HST SYNCHRO 40 / 60 SL
- HST SYNCHRO 40 / 60 MMS

2. SAFETY MEASURES AND RULES OF BEHAVIOR

HST SYNCHRO may be used only in intended sectors. Consider the respective technical data.

An improper use of the HST SYNCHRO tap holder excludes the liability of the manufacturer.

All relevant safety rules and local rules have to be complied with while working with HST SYNCHRO. The safety instructions of the machine or other tools and components have to be considered. Never work with opened machine door.

Eye protection

Please always wear safety goggles with side protection in order to protect your eyes from flying parts.



Adequate clothing

The rotating spindle of a machine tool can seize loose clothing or long hair. During operation of a machine tool, please wear close-fitting clothes. Do not wear jewelry nor a tie nor gloves or similar. Tie back long hair or wear a hairnet.



Correct workpiece clamping

Never hold the workpiece or the clamp of the workpiece by hand. The workpiece has to be fixed on the machine table in a way that it cannot be moved nor turned nor lifted.



- Consider the technical specifications and the dimension ranges of the different HST SYNCHRO tap holders.
- Always keep the tap holder and the components clean. This guarantees an optimal machining quality and the longest possible service life.
- The notes for the HST SYNCHRO apply in correspondence with the instructions of the respective machine tool manufacturer.
- The programming for thread cutting and roll forming is done with the standard synchronous thread cutting cycle.

3. DEFINITIONS

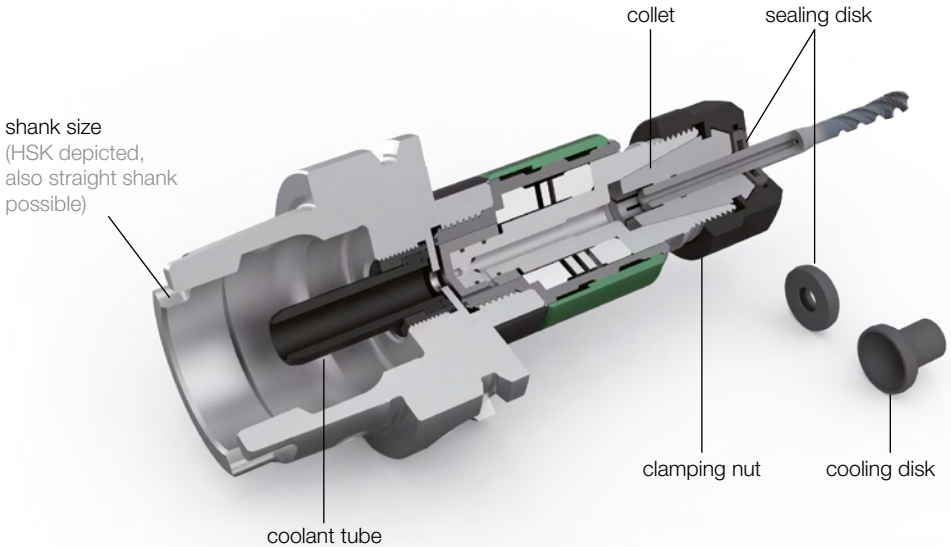

4. APPLICATION

The precondition for the use of a tap holder is a CNC-machine with a synchronized drive spindle. The feed during threading is defined by the thread pitch of the tool. Therefore, the rotation frequency and the feed axis have to be offset against each other constantly.

During this synchronisation, small deviations can occur caused by the CNC-machine (kinematics, control speed, sensor technology) or by the tool (pitch tolerance, thermal expansion).

This difference causes increased axial forces and high pressure on the thread flanks, leading to increased abrasion of the flanks and thus to a reduced tool life.

Our HST SYNCHRO tap holders compensate these synchronization errors in tension and compression, reducing friction in the thread flanks.

This optimizes the tool life of the threading tools, increases the process security and reduces the danger of axial miscut to a minimum.

- Using the HST SYNCHRO in combination with BASS machine taps and roll taps ensures an optimal result. If you have any questions, do not hesitate to ask our sales team.
- On principle, we recommend the use of ER-GB collets.
- ER-GB collets have an integrated internal square and are especially designed for clamping of threading tools. This guarantees an optimal torque transmission and prevents a gliding of the tool.

5. SPECIFICATIONS

- The HST SYNCHRO can be used under normal working temperatures of 10 - 50° C.
- HST SYNCHRO KA is equipped with axial internal coolant (KA) and can be used with lubrication pressure up to 80 bar.
- The HST SYNCHRO series features a minimum length compensation of ± 0.5 mm in compression and tension. Except the HST SYNCHRO 10 with a length compensation of $\pm 0,4$ mm and the HST SYNCHRO 100 with $\pm 1,5$ mm.
- HST SYNCHRO MMS is usable up to max. 10 bar.
- They are to be used on synchronized processing machines only.
- The HST SYNCHRO series is appropriate for thread cutting and thread roll forming.
- Designed for right-hand and left-hand threads.
- The HST SYNCHRO series is washable up to 80 °C.

6. UNPACKING

- Take the HST SYNCHRO as well as the included additional material out of the packaging.
- Check if the scope of delivery corresponds to your order.
- Wipe off the preservative oil with a cloth. Do not use additional cleaning agents or water.
- Immediately check the delivered goods for potential transport damages. Belated complaints in this regard will not be accepted.
- The packaging material has to be disposed according current legal requirements of the respective country.

7. OPERATION

The standard delivery scope of HST SYNCHRO tap holders includes a clamping nut, a coolant tube and an instruction manual. Wrenches, collets, sealing and cooling disks as well as other accessories may be ordered separately.

The HST SYNCHRO can be used basically with any machine or roll tap. However, the best results can be obtained with BASS machine taps of the MHST series. We will be glad to give you more information about this line of high performance taps.

The clamping nut included in the delivery is suitable for threading tools with internal coolant. Additionally, the use of a sealing or cooling disk is required.

When using only internal coolant through the threading tool (KA / KR), a sealing disk has to be used. Otherwise, a major part of the cutting fluid will get lost through the collet. Thus, without a cooling disk, a sufficient lubrication of the cutting area is not guaranteed.

In addition, sealing disks prevent the penetration of dirt and chips into the slots of the collet. Therefore, the use of a sealing disk is recommended, even when working without internal coolant.

Cooling disks enable improved lubrication along the shank. When machining through holes exclusively, a tap without internal coolant can be used.

When tapping through and blind holes with the same tool, we recommend a blind hole tap with axial internal coolant and the use of a cooling disk.

Sealing and cooling disks are available separately for the respective clamping nut size (ER) and shank diameter. You can find them in our latest catalog.

7.1 ASSEMBLY AND CLAMPING

1. Mounting of the sealing disk

Insert the sealing disk into the clamping nut from the rear side and gently push it in by hand. The marking on one side of the sealing disk must be visible when looking into the clamping nut from the rear side.

An audible click noise will tell you that the sealing disk has been mounted correctly into the clamping nut. The sealing disk should flush with the clamping nut at the front.

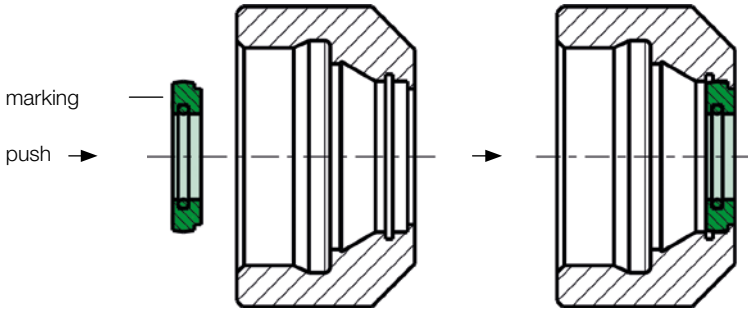

Make sure that the disk is completely clicked into place and flush with the front side of the nut. Otherwise the sealing function of the sealing disk may not work properly.

A sealing disk should be used when working with tools with internal coolant in order to transport as much coolant as possible through the tool.



2. Mounting of the cooling disk

The mounting of the cooling disk works the same way as the mounting of the sealing disk.

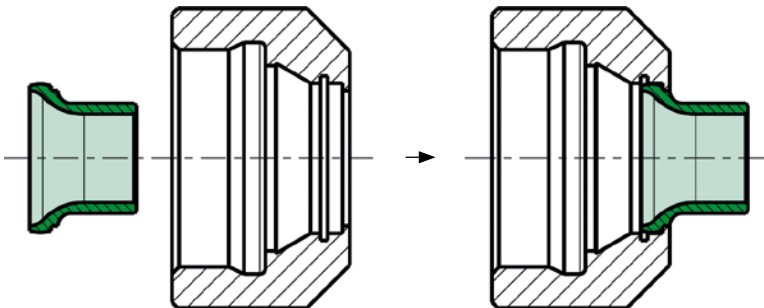

3. Mounting of the ER-GB collet

Insert the groove of the collet into the excentric ring of the clamping nut at the mark on the bottom of the nut (left picture). Tilt the collet in the opposite direction until it audibly engages.

A use without sealing disk is possible (not true for HST SYNCHRO MMS). There remains a little space between the front of collet and the front surface of the clamping nut. However, this space does not affect the functioning.

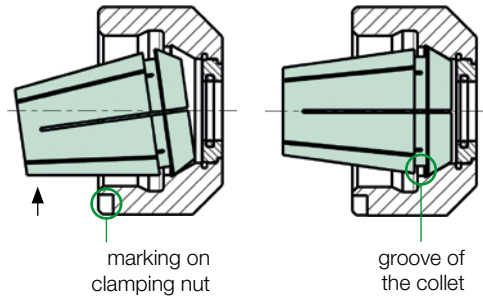

4. Insert the tool

Always insert the tool from the front. First clean the tool from dirt and remaining oil.

When using ER-GB collets, please pay attention that the square of the tool is inserted into the square of the collet.

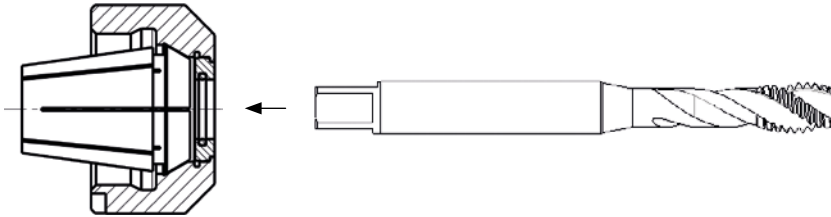

As described above, the tool must be inserted from the front side. Otherwise, the o-ring in the sealing disk will be damaged. Please pay attention not to move the sealing disk.

Follow the instructions carefully.

An improper handling leads to damages and excludes the liability of the manufacturer.

Never place the collet into the cone without latching it into the clamping nut first. Otherwise it might not be possible to remove the collet.

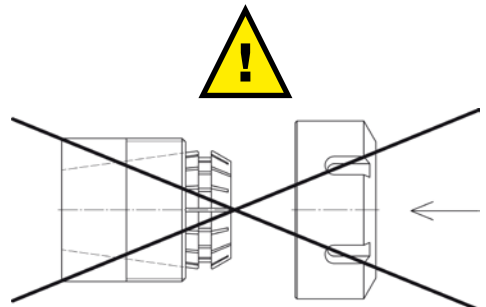

5. Positioning and fastening

Place the clamping nut with the properly mounted collet and threading tool on the thread of the tap holder and screw it on. Tighten the clamping nut with the corresponding set of wrenches.

When fastening the clamping nut, the collet chuck must be fixed with a wrench in order to avoid damage to the tap holder.

Please respect the maximum locking torques of the table below.

Use suitable wrenches to tighten the clamping nut.

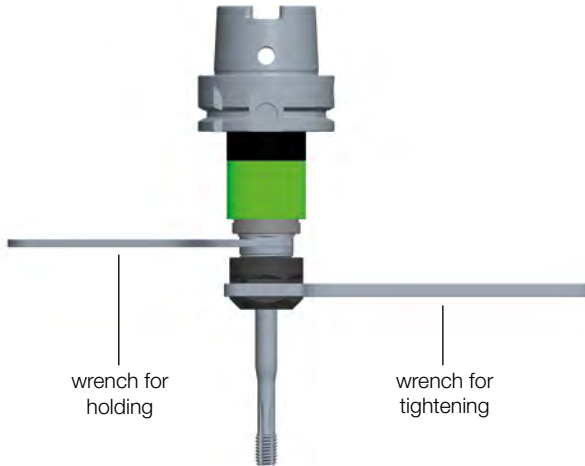

Type	range	recommended / max.
HST SYNCHRO 10 / SL	M1 - M3	6 Nm / 7,5 Nm
HST SYNCHRO 20 / SL	M2 - M5	16 Nm / 20 Nm
HST SYNCHRO 40 / SL / MMS	M4 - M12	35 Nm / 44 Nm
HST SYNCHRO 40 QCA	M4 - M12	28 Nm / 35 Nm
HST SYNCHRO 60 / SL / MMS	M8 - M20	104 Nm / 130 Nm
HST SYNCHRO 60 QCA	M8 - M16	28 Nm / 35 Nm
HST SYNCHRO 80 / SL	M18 - M30	176 Nm / 220 Nm
HST SYNCHRO 100 / SL	M30 - M48	300 Nm / 375 Nm



For secure tightening of the clamping nut, we recommend a torque wrench. By setting the recommended tightening torque, you avoid damages to the tap and tap holder.

Torque wrenches and suitable torque wrench heads for the corresponding clamping nut are to be ordered separately.

7.2 UNCLAMPING OF THE CUTTING TOOL

1. Loosen the clamping nut

Loosen the clamping nut carefully. Hold on to the collet chuck with a wrench as described above – see picture in chapter 5 “Positioning and Fastening”. This avoids damages to the tap holder.

Turn left to loosen the clamping nut. After loosening the nut, there might be another tight point during screwing when the collet unclamps from the cone.

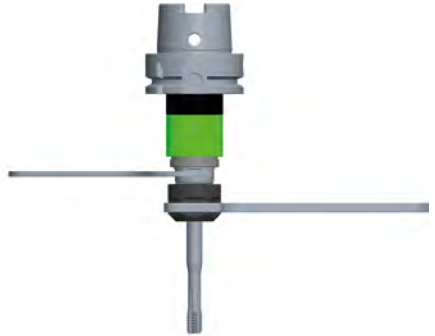

2. Unclamping the cutting tool

Unscrew the clamping nut and remove it from the tap holder.

Pull the threading tool out to the front.

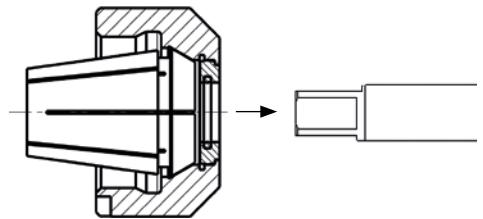

3. Removing the collet

After removing the clamping nut, the collet can be removed. Exert lateral pressure on the collet from the side opposite to the mark on the clamping nut.

The collet disengages audibly from the excentric ring. Now the collet can be removed.

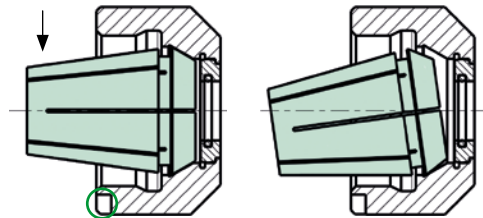

4. Disassembly of sealing disk and cooling disk

To remove the sealing disk, press on the sealing disk from the outside until it disengages. Now you can remove the sealing disk by hand from the clamping nut.

The disassembly of the cooling disk works the same way.

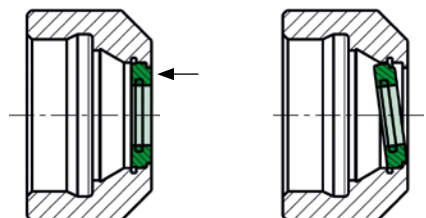

7.3 INSERT AND CHANGE OF THE MQL TUBE

The HST SYNCHRO MMS was designed for Minimum Quantity Lubrication. Minimum Quantity Lubrication is termed as an oil consumption of ≤ 50 ml/h.

Depending on the MQL system, different coolant tubes are to be used for HSK (see DIN 69090), shank size and:

- 1-channel system (automatic tool change)
- 2-channel system (automatic tool change)
- manual tool change (for 1 and 2 channel system)

For a reliable transfer of the aerosol from the machine to the HST SYNCHRO MMS, a special coolant tube has to be mounted.

Before delivery, each HST SYNCHRO MMS gets equipped with a coolant tube according to the machine specifications or the customer's choice respectively. Included in delivery are also a clamping nut DIN ISO 15488, as well as an AES screw (axial adjustment screw) of your choice.

Wrench set, collet, sealing disk and spanner for axial adjustment screw are to be ordered separately.

Information about the MQL system can be requested from the producer or can be found in the instruction manual of the machine tool.

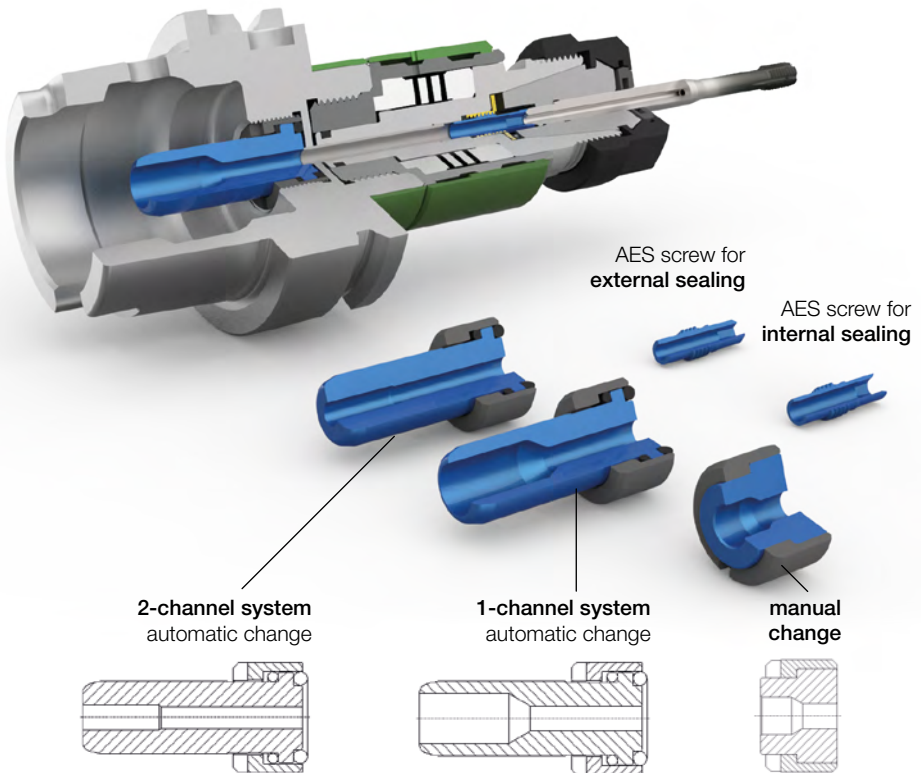

Change of the coolant tube

Put the spanners for coolant tubes (available separately) on the coolant tube. Twist the spanner until the pins of the spanner form-lock with the grooves of the coolant tube.

Then use the spanner, to place the coolant tube straight onto the thread in the HSK cone.

Carefully screw the coolant tube clockwise. Tighten hand-tight to seal it.

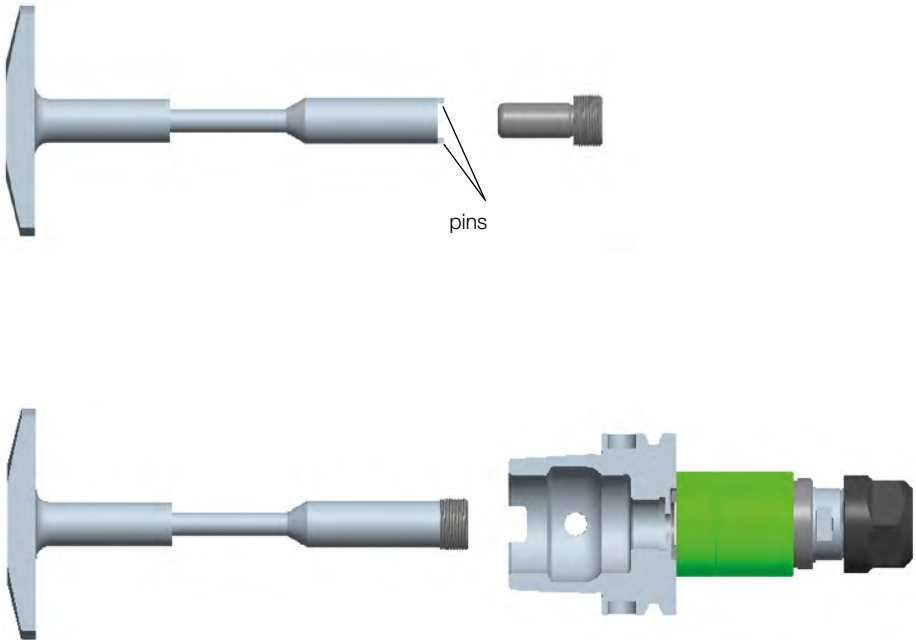

When you loosen the coolant tube, check if the pins of the spanner are form-locked with the grooves of the coolant tube. Only unscrew counter clockwise.

Too strong tightening can lead to damages on the spanner and the sealing ring.

Before each change of the coolant tube, lubricate the o-rings that are located in the coolant tube.



7.4 MOUNTING AND ADJUSTMENT OF AES SCREWS

To adjust the setting length of the threading tool and the tap holder, AES screws (axial adjustment screws) are needed. They also guarantee a secure transfer of the aerosol.

One AES screw (size according to customer preference) is included in the scope of delivery of the HST SYNCRHO MMS. Further AES screws for different shank diameters are available separately.

The AES screw must be selected according to the shank diameter of the threading tool. In our catalog you will find an overview under "HST SYNCHRO axial adjustment screw".

Additionally, the choice of the AES screw depends on the connection type at the square of the threading tool.

- The AES screw has a metric fine thread with a pitch of 1 mm.
- The minimal length adjustment is 3 mm.

In general, we can distinguish between the following connection types:

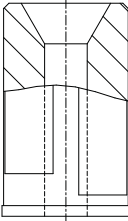
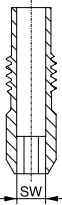
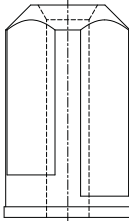
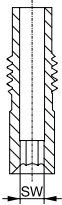
Internal sealing		External sealing	
Internal cone 60° at the tool	AES screw for tool with internal cone	External cone 90° at the tool	AES screw for tool with external cone
			

The AES screw is responsible for a reliable transfer of the aerosol. Choosing the wrong AES can lead to an accumulation of aerosol in the tap holder. In this case, a continuous lubrication cannot be ensured. The tool life drops and tool breakages may occur.

Do not adjust the screws while the clamping nut is tightened. The setting of the length can be done with a long hexagon socket wrench (to be ordered separately) from the shank side or through the collet.



Setting from the shank side

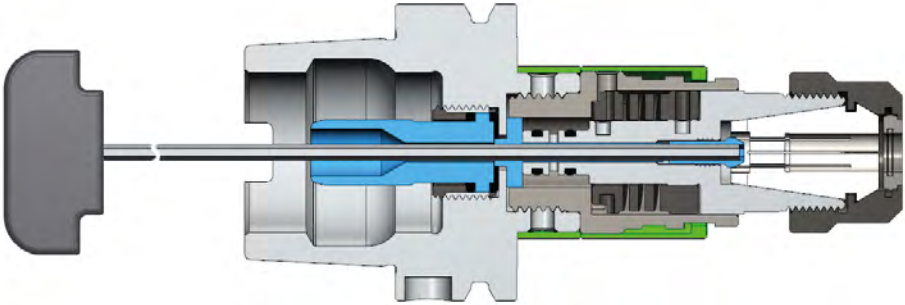

Setting through the collet

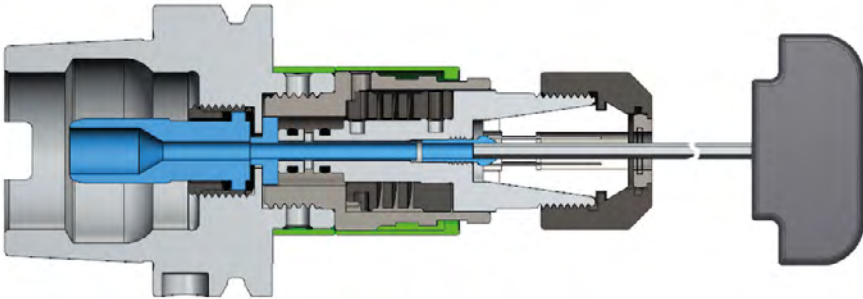

Inserting the AES screw

Insert the spanner into the AES screw. Place the AES screw on the thread and screw it in slowly. Set the desired length. If the AES turned to the end-stop, loosen it with one rotation. This guarantees the springy bearing and prevents damages on the spanners and AES screws.

The effective insertion depth can deviate from the depth calculated from tool and spanner dimensions according to DIN standard.

You can find the insertion depth E for the respective collet in our catalog.

Calculation setting length
Length HST SYNCHRO
+ tool length
- insertion depth
= setting dimension

The tightening of the clamping nut pushes the threading tool slightly against the AES screw. In order to avoid damage of the AES screw, please proceed as follows:

1. adjust the setting length
2. tighten the clamping nut by hand
3. slightly loosen the AES screw
4. tighten the clamping nut with the recommended torque
5. retighten the AES screw



8. HST SYNCHRO QCA 40 / 60

Our tap holder with quick change adapter allows tool change in the machine without using additional aids like wrenches.

8.1 ASSEMBLING AND CLAMPING

For the assembly of sealing disk, collet and tool see chapter 7.1.

8.2 INSERT QUICK CHANGE ADAPTER

Position the quick change adapter in front of the tap holder. Clean the mounting surface beforehand.

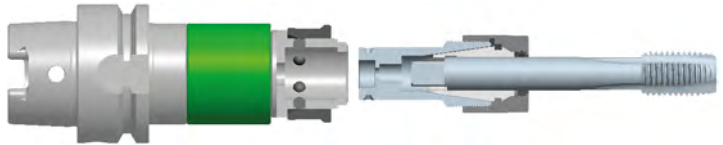

Pull the expansion coupling on the HST SYNCHRO forwards in direction of the arrow.

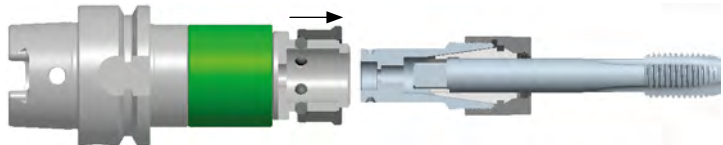

Hold the expansion coupling and insert the quick change adapter into the tap holder.

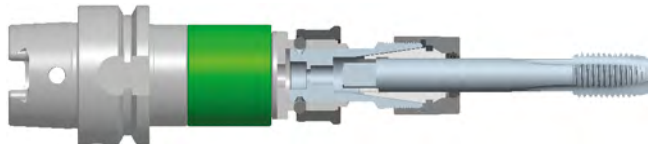

Release the expansion coupling. Slowly turn the quick change adapter until it locks in place. Check if the expansion coupling has latched completely. If necessary, push the coupling backwards in direction of the arrow.

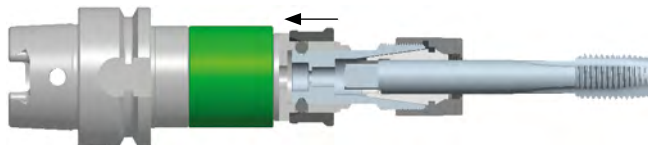

The HST SYNCHRO QCA should always be used with its especially developed quick change adapter. Conventional quick change adapters have too

much clearance which affects the functioning of the minimum length compensation significantly.

9. MAINTENANCE

A special maintenance of the technical components is not necessary.

10. CARE

- The HST SYNCHRO is washable up to 80 °C.
- After use, please remove all remaining lubricant and dirt accumulation.
- When cleaning, do not use any solvent.
- After use or cleaning, moisten the tap holder with anticorrosive oil.

11. CHECKLIST FOR OPTIMAL TAPPING

- Check if the cutting tap is still useable and if it has the right geometry for the intended application.
- Check if the tap is correctly aligned with the bore hole.
- Check if the rpm of the machine spindles has been programmed correctly.
- Are feed and feed stop programmed correctly so that the tap will not hit the bottom of the bore hole and break?
- Check if the workpiece is clamped firmly and that it will not become loose during machining.
- Did you pre-drill a bore hole with the correct diameter?
- When tapping through holes, the whole chamfer of the threading tool must be able to protrude out of the bore.
- Did you choose the right coolant / lubricant for the threading tool?
- If you want to tap a blind hole, check if there is enough space for the chips.

12. CHECKLIST FOR OPTIMAL THREAD FORMING

- Check if the roll tap is still useable and if it has the right geometry for the intended application.
- Check if the roll tap is correctly aligned with the bore hole.
- Check if the rpm of the machine spindles has been programmed correctly.
- Are feed and feed stop programmed correctly so that the tap will not hit the bottom of the bore hole and break?
- Check if the workpiece is clamped firmly and that it will not become loose during machining.
- Did you pre-drill a bore hole with the correct diameter?
- When tapping through holes, the whole chamfer of the threading tool must be able to protrude out of the bore.
- Did you choose the right coolant / lubricant for the threading tool?



BASS GmbH
Technik für Gewinde
Bass-Strasse 1
97996 Niederstetten
Deutschland · Germany

Tel.: +49 7932 892-0
Fax: +49 7932 892-87
E-Mail: info@bass-tools.com
Web: www.bass-tools.com



subject to modifications

edition 04/2019