

EMAG BMT 55-83

Live Tools & Static Holder

Tooling & Machine Tooling Technology

Metal machining

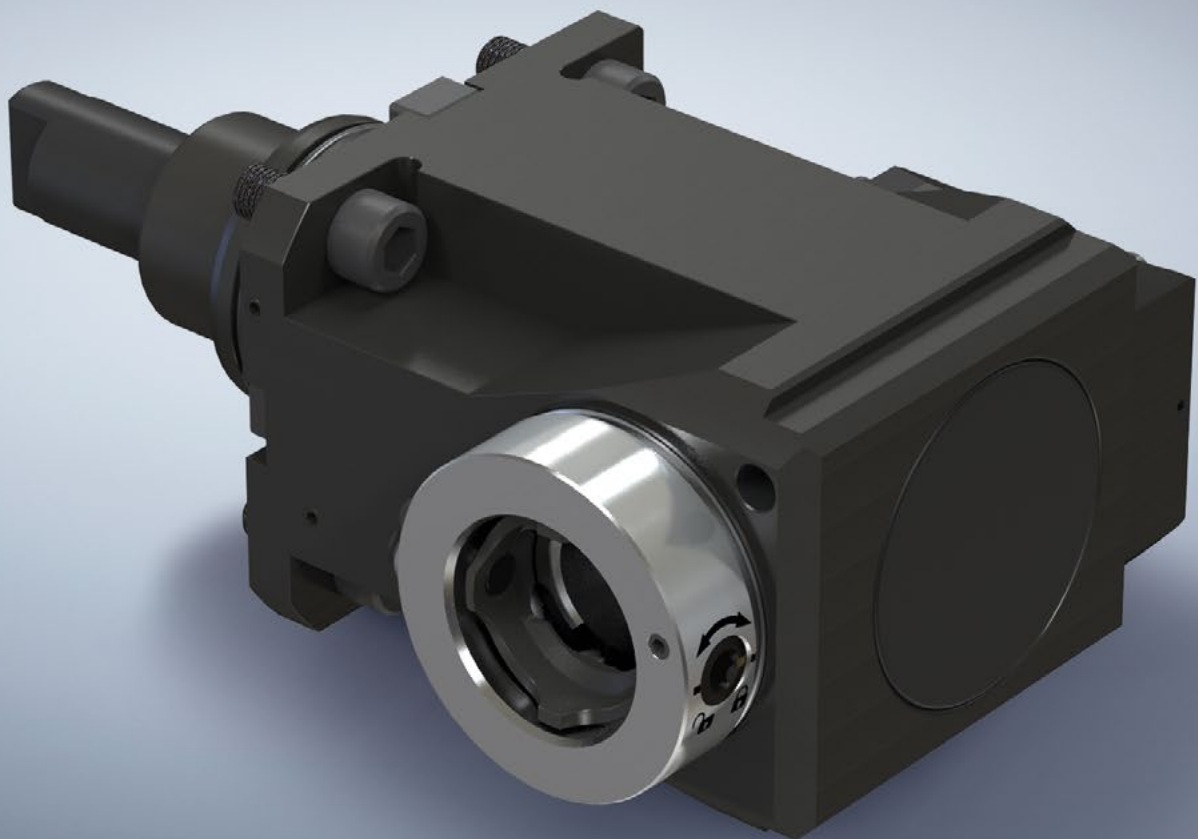



AT BENZ GMBH WERKZEUGSYSTEME, OUR MAXIM, INNOVATION, PRECISION, PASSION, IS FAR MORE THAN JUST A MARKETING FORMULA. RATHER, IT DESCRIBES THE CORE GOALS OF OUR BUSINESS WHILE ALSO OUTLINING THE REASONS WHY WE HAVE BEEN ABLE TO COMPETE IN THE MARKET SUCCESSFULLY WITH TOOL SYSTEMS FOR WOODWORKING, METAL MACHINING AND COMPOSITE MATERIAL PROCESSING FOR MORE THAN 30 YEARS.



INNOVATIONS ARE IMPORTANT TO US. BUT WE ALSO RECOGNIZE THAT THEY CAN BE SUCCESSFUL ONLY IF THEY PRECISELY MEET THE NEEDS OF OUR CUSTOMERS. THIS IS WHY WE HAVE MAINTAINED A STRICT FOCUS ON OUR CUSTOMERS FOR MANY YEARS. WE ENSURE THAT OUR DEVELOPMENTS AND INNOVATIONS SIMPLIFY YOUR PRODUCTION PROCESSES AND LOWER YOUR MANUFACTURING COSTS - AND ULTIMATELY IMPROVE YOUR COMPETITIVENESS AS A RESULT.



BENZ TOOLING TECHNOLOGY FOR EMAG LATHES BMT 55-83

BENZ STANDARD PRODUCT RANGE - FITS FOR:

MACHINES

			 SW	 AL	 TYPE
EMAG VL	2	4	330	83	STD
EMAG VLC	100 (VL2)		340	83	HSP
EMAG VT2			360	83	STD
EMAG VTC	100 (VT2)		360	83	HSP

 Further tools upon request



More information about our BENZ products and accessories can be found at the download area of our website.

<https://www.benztooling.com/en/services/downloads>



BMT 55-83

Live Tools | Static Holders



LIVE TOOLS



AXIAL

6



AXIAL, 1:2

7



RADIAL

8



RADIAL, 1:2

9



ADJUSTABLE

10



BROACHING UNIT AXIAL

11

STATIC HOLDERS



STANDARD

12



BENZ CAPTO™

13

LIVE TOOL BMT 55-83

AXIAL

TECHNICAL DATA



OUTPUT SPINDLES



BENZ
Solidfix®



Collet chuck
System ER
DIN 6499



BENZ
CAPTO™

i Other output spindles available upon request



BENZ Solidfix® / Collet chuck

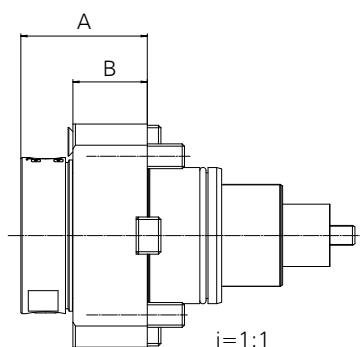

BENZ CAPTO™

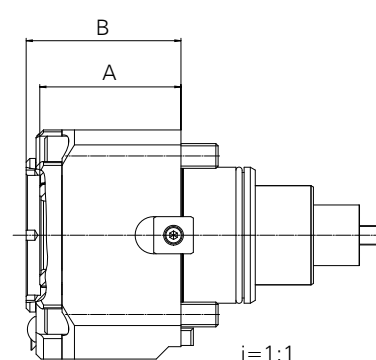

Output spindle	Technical Data							Order No.	
	Size Spindle	i	EC	IC p _{max} [bar]	n _{1 max} / n _{2 max} [rpm]	M _{1 max} / M _{2 max} [Nm]	A _{max} [mm]		B [mm]
BENZ Solidfix®	S4	1:1	✓	-	6000 / 6000	50 / 50	51	30	113DA07800S4
	S4	1:1	✓	70	6000 / 6000	50 / 50	51	30	113EA07800S4
	S3	1:1	✓	-	12000 / 12000	50 / 50	49	30	113DA07800S3
	S3	1:1	✓	70	12000 / 12000	50 / 50	49	30	113EA07800S3
Collet chuck	ER32	1:1	✓	-	6000 / 6000	50 / 50	55,1	30	113DA07800E6A
	ER32	1:1	✓	70	6000 / 6000	50 / 50	60,2	30	113EA07800E6A
	ER25	1:1	✓	-	12000 / 12000	50 / 50	42,9	30	113DA07800E5A
	ER25	1:1	✓	70	12000 / 12000	50 / 50	47,9	30	113EA07800E5A
BENZ CAPTO™	C4	1:1	✓	-	6000 / 6000	50 / 50	57	62,5	113DA07800L4BD
	C4	1:1	✓	70	6000 / 6000	50 / 50	57	62,5	113EA07800L4BD
	C3	1:1	✓	-	12000 / 12000	50 / 50	49	53,5	113DA07800L3BD
	C3	1:1	✓	70	12000 / 12000	50 / 50	49	53,5	113EA07800L3BD

■ High Speed

LIVE TOOL BMT 55-83

AXIAL, 1:2

TECHNICAL DATA



BENZ Solidfix® / Collet chuck

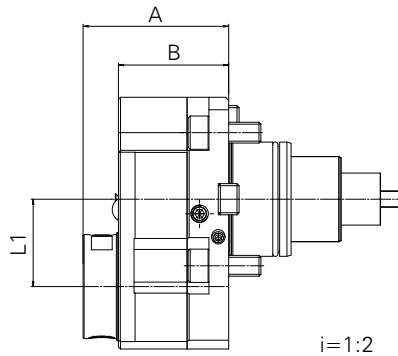

OUTPUT SPINDLES



BENZ Solidfix®



Collet chuck System ER
DIN 6499

BENZ CAPTO™



Other output spindles available upon request

Output spindle	Technical Data									
	Size Spindle	i	EC	IC p _{max} [bar]	n _{1 max} / n _{2 max} [rpm]	M _{1 max} / M _{2 max} [Nm]	A _{max} [mm]	B [mm]	L1 [mm]	Order No.
BENZ Solidfix®	S3	1:2	✓	-	6000 / 12000	30 / 15	70	53	42	113DI07894S3D
	S3	1:2	✓	100	6000 / 12000	30 / 15	77	60	42	113EI07894S3D
Collet chuck	ER25	1:2	✓	-	6000 / 12000	30 / 15	71,9	53	42	113DI07894E5AD
	ER25	1:2	✓	100	6000 / 12000	30 / 15	83,9	60	42	113EI07894E5AD

LIVE TOOL BMT 55-83

RADIAL

TECHNICAL DATA



LENGTH L1

85

OUTPUT SPINDLES



BENZ
Solidfix®



Collet chuck
System ER
DIN 6499



BENZ
CAPTO™

i Other output spindles available upon request



BENZ Solidfix® / Collet chuck

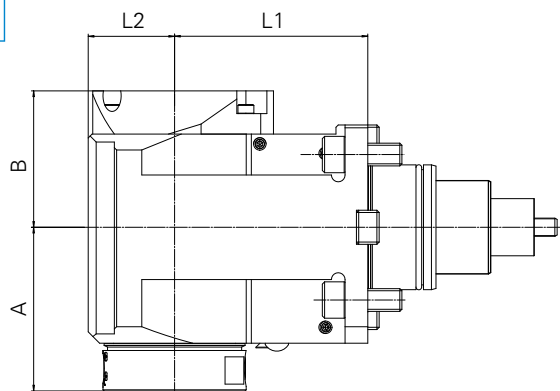

BENZ CAPTO™

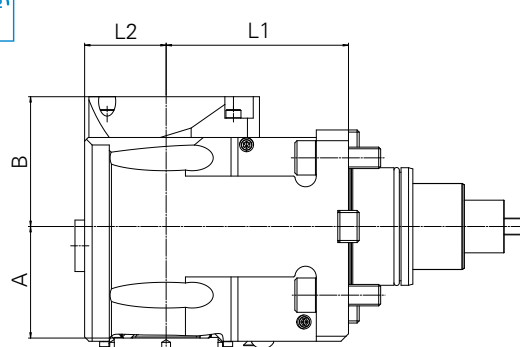

Technical Data

Output spindle	Size Spindle	i	EC	IC p _{max} [bar]	n _{1 max} / n _{2 max} [rpm]	M _{1 max} / M _{2 max} [Nm]	A _{max} [mm]	B [mm]	L1 [mm]	L2 [mm]	Order No.
BENZ Solidfix®	S4	1:1	✓	-	6000 / 6000	70 / 70	72	52	85	38	113FAX07849S4D-85
	S4	1:1	✓	100	6000 / 6000	70 / 70	72	60	85	38	113GAX07849S4D-85
	S3	1:1	✓	-	12000 / 12000	30 / 30	56	40	85	28	113FAX07839S3D-85 ■
	S3	1:1	✓	100	12000 / 12000	30 / 30	56	58	85	28	113GAX07839S3D-85 ■
Collet chuck	ER32	1:1	✓	-	6000 / 6000	70 / 70	69,1	52	85	38	113FAX07849E6AD-85
	ER32	1:1	✓	100	6000 / 6000	70 / 70	74,2	60	85	38	113GAX07849E6AD-85
	ER25	1:1	✓	-	12000 / 12000	30 / 30	56,9	40	85	28	113FAX07839E5AD-85 ■
	ER25	1:1	✓	100	12000 / 12000	30 / 30	61,9	58	85	28	113GAX07839E5AD-85 ■
BENZ CAPTO™	C4	1:1	✓	-	6000 / 6000	70 / 70	52	54	85	38	113FAX07849L4BD-85
	C4	1:1	✓	100	6000 / 6000	70 / 70	52	60,5	85	38	113GAX07849L4BD-85
	C3	1:1	✓	-	12000 / 12000	30 / 30	42	45	85	32	113FAX07839L3BD-85 ■
	C3	1:1	✓	100	12000 / 12000	30 / 30	42	67,5	85	32	113GAX07839L3BD-85 ■

■ High Speed

LIVE TOOL BMT 55-83

RADIAL, 1:2

TECHNICAL DATA



LENGTH L1

85

OUTPUT SPINDLES



BENZ Solidfix®



Collet chuck System ER DIN 6499

BENZ CAPTO™



Other output spindles available upon request



BENZ Solidfix® / Collet chuck

BENZ CAPTO™

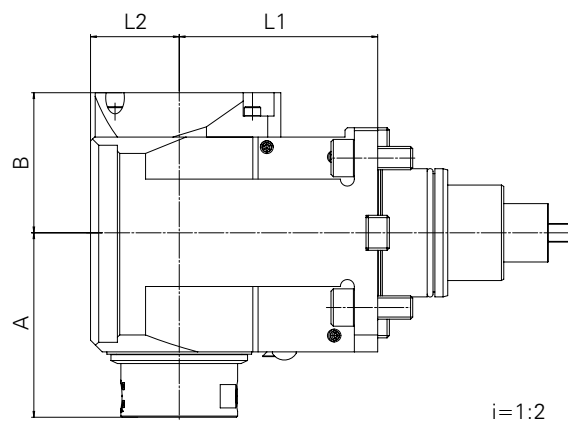

Technical Data

Output spindle	Size	i	EC	IC	p _{max} [bar]	n _{1 max} / n _{2 max} [rpm]	M _{1 max} / M _{2 max} [Nm]	A _{max} [mm]	B [mm]	L1 [mm]	L2 [mm]	Order No.
BENZ Solidfix®	S3	1:2	✓	-		5000 / 10000	40 / 20	79	52	85	38	113FWX07849S3D-85
	S3	1:2	✓	✓		5000 / 10000	40 / 20	79	60	85	38	113GWX07849S3D-85
Collet chuck	ER25	1:2	✓	-		5000 / 10000	40 / 20	78,6	52	85	38	113FWX07849E5AD-85
	ER25	1:2	✓	✓		5000 / 10000	40 / 20	83,6	60	85	38	113GWX07849E5AD-85

LIVE TOOL BMT 55-83

ADJUSTABLE

TECHNICAL DATA



OUTPUT SPINDLE

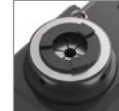

Collet chuck
System ER
DIN 6499

i Other output spindles
available upon request



Collet chuck

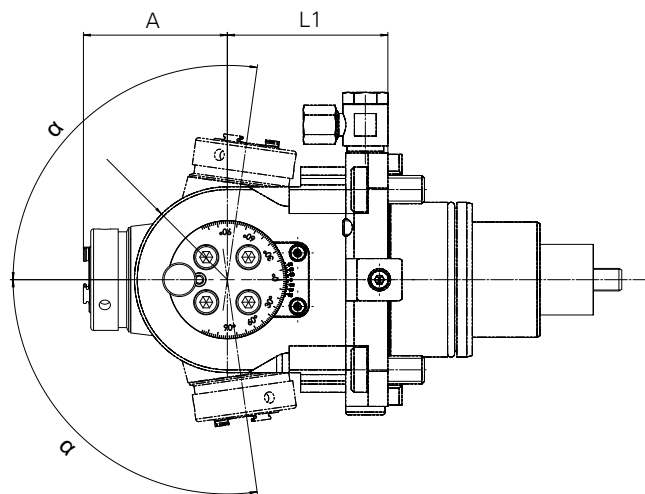

Technical Data

Output spindle	Size Spindle	i	EC	IC p _{max} [bar]	n _{1 max} / n _{2 max} [min ⁻¹]	M _{1 max} / M _{2 max} [Nm]	A _{max} [mm]	L1 [mm]	α [°]	Order No.
BENZ Solidfix®	S1	1:0,879	✓	-	8000 / 7000	10 / 12	46	57	98	113FDX09439S1
	S1	1:0,879	✓	50	8000 / 7000	10 / 12	46	57	98	113GDX09439S1
Collet Chuck	ER16	1:0,879	✓	-	8000 / 7000	10 / 12	51,1	57	98	113FDX09439E3A
	ER16	1:0,879	✓	50	8000 / 7000	10 / 12	56	57	98	113GDX09439E3A

*Internal cooling p_{max} = 50 bar

LIVE TOOL BMT 55-83

AXIAL, BROACHING UNIT - BENZ LINA 4.0

TECHNICAL DATA



i.com

LENGTH L1

88

OUTPUT SPINDLE



Prism-shaped profile
Ø 30 mm

i For questions regarding BENZ i.com please contact our BENZ Sales Team

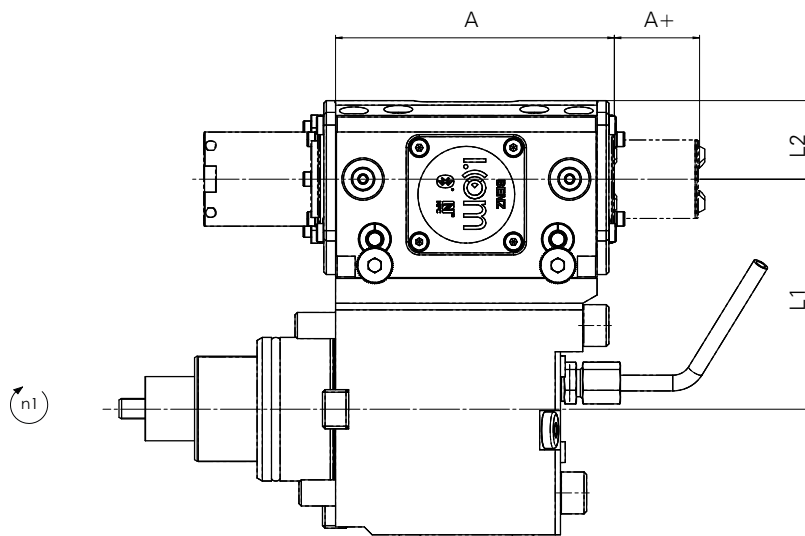

Performance Data

Type	$n_{1\max} / *n_{2\max}$ [min ⁻¹]	$M_{1\max} / F_{c\max}$ [Nm]	f [mm]	Groove width _{max} [mm]
ES	1500 / 1500	30 / 1700	0,02 - 0,10	12

Technical Data

Type	Size	i	EC	IC p _{max} [bar]	**A+	A [mm]	L1 [mm]	L2 [mm]	Order No.
ES	30	1:1	✓	50	32 / 34	106,5	88	30	113ES07807B2D-88-IB

*number of double stroke per minute

**usable working stroke / total stroke

STATIC HOLDERS – BMT 55

O.D. TURNING TOOL | SINGLE

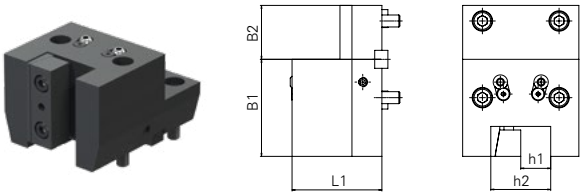
Model	Drawing	Technical Data					EC	IC	Order No.
		h1 [mm]	h2 [mm]	L1 [mm]	B1 [mm]	B2 [mm]			
		25	50	75	81	45	✓	✓	113A078560001
		25	50	75	81	45	✓	✓	113A078560001-IC

BORING BAR HOLDER | SINGLE

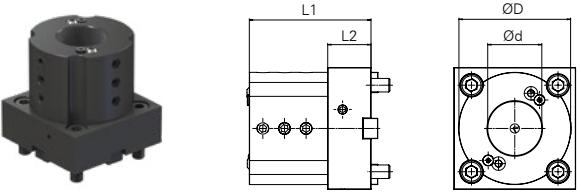
Model	Drawing	Technical Data				EC	IC	Order No.
		Ød [mm]	ØD [mm]	L1 [mm]	L2 [mm]			
		40	83	90	32	✓	✓	113A078576005

REDUCING SLEEVE

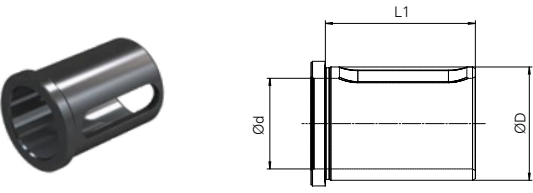
Model	Drawing	Technical Data			Order No.*
		Ød [mm]	ØD [mm]	L1 [mm]	
		32	40	69	B571-403269L
		25	40	69	B571-402569G
		20	40	69	B571-402069G
		16	40	69	B571-401669G

*Versions: L= with slotted hole / G= with threads

AXIAL HOLDER | SINGLE - BENZ CAPTO™

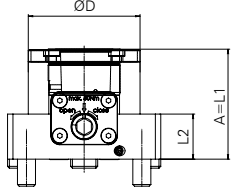
Model	Drawing	Technical Data					Order No.	
		Size Adapter [mm]	A [mm]	ØD [mm]	L1 [mm]	L2 [mm]		IC
								
								
		C4	61	62	61	25	✓	113AA078L4BDU-61
		C5	73	77	73	25	✓	113AA078L5BDU-73

RADIAL HOLDER | SINGLE - BENZ CAPTO™

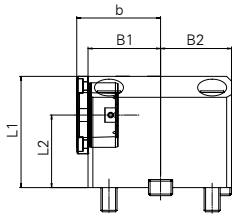
Model	Drawing	Technical Data					Order No.		
		Size Adapter [mm]	L1 [mm]	L2 [mm]	b [mm]	B1 [mm]		B2 [mm]	IC
									
									
		C4	69	45	52	45	44	✓	113AP078L4BDU-45
		C5	77	45	58	45	44	✓	113AP078L5BDU-45

RADIAL HOLDER | SINGLE - BENZ CAPTO™

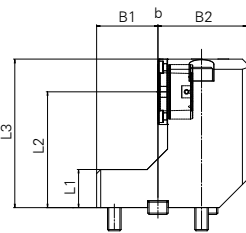
Model	Drawing	Technical Data						Order No.		
		Size Adapter [mm]	L1 [mm]	L2 [mm]	L3 [mm]	b [mm]	B1 [mm]		B2 [mm]	IC
										
										
		C4	28	85	109	0	45	65	✓	113AR078L4BDU-85
		C5	28	85	117	0	45	77	✓	113AR078L5BDU-85

PRODUCT GROUPS

TOOLING & MACHINE TOOLING TECHNOLOGY

TOOLING TECHNOLOGY



METAL

LIVE TOOLS/TOOL HOLDERS

- Radial heads 90°
- Radial heads ≠ 90°
- Axial heads
- Swivel heads
- Multi-spindle heads
- Broaching units
- Rotating tool holders
- Static tool holders

COMPONENTS. Our comprehensive tool concepts for turning centers and milling centers are ideal for nearly every application. Providing a technological advantage is our goal.

SPECIFIC TO THE CUSTOMER. Our modular approach enables customized configurations.

SYSTEMS. We develop special customer-specific tools for OEM and end customers on request.



METAL

EXCHANGEABLE UNITS

- Angle heads 90°
- Angle heads ≠ 90°
- Swivel heads
- Multi-spindle heads
- Broaching units
- High-speed spindles

KNOWLEDGE AND EXPERIENCE. Our knowledge of the metalworking industry and decades of development partnership make us ideal for new tasks anywhere in the world.

COMPONENTS. We deliver a vast array of standard components from stock and develop innovative, customized systems for OEM and end customers.

VARIETY. Whether in machining centers in the automotive, aerospace or wind energy industries, units from Benz can be used anywhere. Numerous customers choose us as their systems and innovation partner.



WOOD / COMPOSITE AND ALUMINIUM

EXCHANGEABLE UNITS

- Angle heads 90°
- Swivel heads
- Multi-spindle heads
- Multi-axis heads
- Sanding units
- Floating head units

FOR ANY APPLICATION. Cost-effectively process and machine wood, composites and aluminium: We provide series production angle heads for drilling, milling, sawing and grinding in addition to other units for special applications.

FROM BASIC TO HIGH-END. Benz units are available in a variety of performance classes, making them ideal for everything from light machining to high-performance continuous operation.

SYSTEMS. We have the solution for your special applications: Customized Benz units for machining centers. Put us to the test!

MACHINE TOOLING TECHNOLOGY

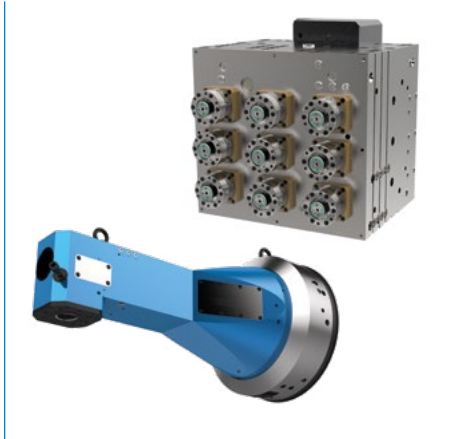

METAL

MULTI-SPINDLE HEADS AND LARGE DRILL HEADS

- Large angle heads
- Large drill heads
- XXL multi-spindle heads

DEVELOPMENT PARTNER. We accompany you from brainstorming to inspection of the final machine, always to your expectations. Our assortment ranges from compact heads to XXL units.

SYSTEMS. Benz stands for high-end solutions in the fields of machine tooling technology, specialty solutions, custom assemblies and mechanical modules. We manufacture and configure multiple-spindle and large-angle heads as well as large drill heads.

COMPONENTS. Attachment units complete our range.



METAL / WOOD / COMPOSITE AND ALUMINIUM

SYSTEM TECHNOLOGY

- Multiple-spindle drill heads
- Motor spindles
- Motors
- 5-axis technology
- C-axes
- Swivel axes
- Rotary distributors
- Z-axes

COMPONENTS. Our range includes standard products in an assortment of shapes and sizes.

THE PERFECT ADDITION. Our system additions provide you with even more efficiency. Perfect your existing solutions with Benz products!

SYSTEMS. We develop the technology of tomorrow. Your individual requirements for the efficiency of your machine tools and the suitability of the tools in use provide our benchmark for new, innovative solutions.

SERVICE

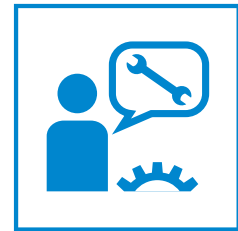

METAL / WOOD / COMPOSITE AND ALUMINIUM

SERVICE

- Repair service
- Rapid Repair Kit
- Preventive maintenance
- Spare part management
- Global service
- Service hotline

DO NOT LOSE A SECOND. Speed is the order of the day when unexpected breakdowns occur. Our service center ensures immediate assistance around the world. We ensure your machine has as little downtime as possible.















SERVICE QUALITY. We guarantee top service quality reflecting our expertise as a manufacturer.

FORESIGHT. We go one step further: Preventive maintenance, customized Rapid Repair Kits and our spare part management service ensure you have the best setup to face any emergency. We look to the future to keep you at your peak.

OVERVIEW

PICTOGRAMS & ABBREVIATIONS

UNIT SPECIFICATIONS

Type of machining	 <p>Drilling is suitable for boring machining</p>	 <p>Milling is suitable for milling machining</p>	 <p>Threading is suitable for thread machining</p>	 <p>Broaching and slotting is suitable for machining by broaching and slotting</p>
Number of output spindles (tool holding fixtures)	 <p>1 one output spindle</p>			
Axis angle	 <p>0° Unit for machining tasks at a 0° angle</p>	 <p>90° Unit for machining tasks at a 90° angle</p>	 <p>± 0 Unit for machining tasks at an adjustable angle 0° ± max. α°</p>	
Drive for spindle	 <p>clockwise / clockwise synchronized rotation</p>		 <p>clockwise / counterclockwise counter-rotation</p>	
Direction of rotation				
Coolant feed for cutting blade	 <p>Extern (EC) The tool is cooled using an external feed line (spray nozzle)</p>	 <p>Combination (EC+IC) The tool is cooled by a combination of both internal and external systems</p>		
Turret data	 <p>Width across / Turret width</p>	 <p>Drive length of the tools shank in the turret</p>	 <p>Turret type</p>	

ABBREVIATIONS

M_{max}	Maximum torque
i	Gear ratio
n_{max}	Maximum speed
f_c	Feed
P_{max}	Maximum pressure (bar)
EC	External cooling
IC	Internal cooling
p.	Page
✓	Possible
-	Not possible
SW	Width across flats
mm	Millimeter

Usage note – general

The contents of this catalog are not legally binding and are intended solely for informational purposes. Any final agreement will be in the form of a written order confirmation from BENZ GmbH, which occurs only subject to the respective current General Terms and Conditions of Sale and Delivery of BENZ GmbH. These can be found online at www.benz-tools.de.

All of the products listed in this catalog are designed for their intended use, e.g. machines for precision machining. The recognized technical regulations for safety and professional work must be followed for use and installation.

Furthermore, the respective laws, guidelines from TÜV, guidelines from the respective trade association and VDE stipulations shall apply.

The technical data listed in this catalog must be observed by the user. The conditions of use may not fall below or exceed the specified data. If information is missing, it cannot be assumed that there are no upper or lower limits or no limitations for specific use cases. Consultation is required in these cases.

Disposal is not included in the price, which would have to be taken into account accordingly in the event of return to or disposal by BENZ GmbH.

TECHNICAL DATA AND FIGURES

The technical data and figures have been compiled with great care and to the best of our knowledge. We cannot guarantee that the information is up to date, correct or complete.

The specifications and information - such as figures, drawings, descriptions, dimensions, weights, materials, technical and other performance data and the described products and services - contained in general product descriptions, BENZ GmbH catalogs, brochures and price lists in any form are subject to change and may be modified or updated at any time without prior notification. They are binding only to the extent expressly specified in a contract or order confirmation. Slight deviations from such descriptive product information shall be considered approved and shall not affect fulfillment of agreements insofar as they are reasonable for the customer.

LIABILITY

Products from BENZ GmbH are subject to the German Product Liability Act. This catalog does not contain any guarantees, assurances of quality or procurement agreements for the products it depicts, neither expressly nor implied, including for the availability of products. Advertising statements relating to quality features, properties or applications for the products are not legally binding.

To the extent permitted by law, BENZ GmbH is exempt from any liability for direct or indirect damage, subsequent damage and requests of any kind or on any legal basis resulting from the use of information contained in this catalog.

TRADEMARK, COPYRIGHT AND REPRODUCTION

The depiction of commercial property rights in this catalog - such as brands, logos, registered trademarks or patents - does not include the granting of licenses or use rights. Their use is not permitted without the expressed written agreement of BENZ GmbH. All contents of this catalog are the intellectual property of BENZ GmbH. For the purposes of copyright, any unlawful use of intellectual property, including excerpts, is prohibited. Reprinting, copying or translating (including in the form of excerpts) are permitted only with the prior written consent of BENZ GmbH.

STANDARDS

BENZ GmbH Werkzeugsysteme has a quality management system certified in accordance with ISO 9001:2008. BENZ GmbH Werkzeugsysteme has an environmental management system certified in accordance with ISO 14001:2004.

Usage note – individual

DECLARATION OF INCORPORATION IN TERMS OF THE EC DIRECTIVE 2006/42/EC ON MACHINERY (ANNEX II 1 B)

We hereby declare that our products meet the basic requirements of the Machinery Directive 2006/42/EC as an incomplete machine to the extent that this is possible as part of delivery.

We also declare that the specific technical documents were produced in accordance with Annex VII Part B of this Directive. We undertake to provide the market supervisory bodies with versions of the incomplete machine's special documents via our documentation department should they have reason to request them.

The incomplete machine also satisfies the stipulations of EC Directive 2014/30/EU on electromagnetic compatibility. The protective goals of EC Directive 2014/35/EU regarding electronic equipment have been met.

The incomplete machine may only be commissioned if it has been ascertained, if applicable, that the machine or system in which the incomplete machine is to be installed satisfies the requirements of Directive 2006/42/EC on Machinery and an EC declaration of conformity has been drawn up in accordance with Annex II.

The contents and data are valid at the time of printing. Edition 08/2021

This catalogue was issued with great care and all specifications were checked for correctness. However, no liability is assumed for incorrect or incomplete information. BENZ GmbH Werkzeugsysteme reserves the right to make technical changes and improvements through continual further development of the products and services. All texts, images, representations and drawings in

this catalogue are the property of BENZ GmbH Werkzeugsysteme* and are protected by copyright. Any kind of reproduction, editing, modification, translation, filming or processing and saving in electronic systems is prohibited without the consent of BENZ GmbH Werkzeugsysteme.

BENZ GmbH Werkzeugsysteme

Im Mühlegrün 12
D-77716 Haslach
T +49 7832 704-0
F +49 7832 704-8001
info@benztooling.com
www.benztooling.com

